



TRANSIT PRODUCTS CATALOG

LB Foster®

lbfooster.com

2
0
1
8

TRANSIT PRODUCTS

L.B. Foster provides transit solutions that deliver products customized to meet your specific needs, constraints, and schedules. Backed by ISO 9001:2015 registration, we take pride in providing superior quality, unparalleled expertise, and reliable customer service for the transit industry. L.B. Foster offers products and services globally for both heavy rail and light rail transit systems.

For the heavy rail transits, we offer direct fixation fastener and contact rail systems. The bonded or non-bonded direct fixation fasteners offer the best balance for noise and vibration dampening, electrical isolation and ease of installation. These systems can be utilized in turnouts, crossings, expansion joints, restraining rails and many other applications. The contact rail systems can consist of steel, aluminum or steel/aluminum clad rails and can be offered as a complete package with insulators, coverboard systems, end approaches, anchors and other appurtenances.

For the light rail transit markets, we provide embedded track systems in addition to direct fixation fastenings. Whether embedded in concrete, asphalt or grass, our rail boot systems can provide resilient solutions to protect the track structure. These systems provide electrical isolation as well as noise and vibration dampening to protect and preserve the environment. We offer a protective boot to fit any rail section and the accessories to support your custom solution. The accessories typically include steel or composite leveling beams, splice cuffs, rail clip systems, fabricated steel plates and miscellaneous installation material.

We also supply hybrid products that apply across the light and heavy rail transit and freight railroad markets. These products include two-block ties, ballast mats, direct fixation fasteners and concrete anchoring assemblies among others.

L.B. Foster also provides engineering and testing services. Our dedicated R&D department and experienced engineers, with the aid of solid modeling and finite element analysis, can customize a solution for your specific needs and prove it out in our own custom laboratory. The testing facility at our Transit Products lab in Suwanee, GA is state-of-the-art and designed specifically for the transit and railroad industries. The laboratory's expertly trained technicians can perform static, fatigue, electrical and environmental tests to simulate in situ conditions. Our on-site lab allows us to speed up product cycles to serve you even faster without compromising product integrity.

Our products are currently operating in nearly every rapid transit rail system in North America and select systems throughout the world. We welcome the opportunity to assist you with your transit needs; please contact us to discover the difference that L.B. Foster will make on your next project.

Designed, developed, laboratory proven and field validated, these track fastener systems offer unique advantages to trackwork engineers and maintenance personnel.

The fastener designs are economical, easy to install and maintain, corrosion resistant, and quiet under load. They have an inherent design flexibility to meet a wide range of performance specifications. For example:

- High or low longitudinal restraint to accommodate various system requirements
- High or low lateral and vertical spring rate characteristics to meet noise/vibration requirements for either heavy or light vehicle systems
- Rigid, resilient or captive spring clip design to attach the rail to the fastener body
- Direct installation capability to concrete slab, wood ties or steel ties
- Outstanding electrical isolation for protection of stray current flow

The L.B. Foster Transit Products Division can provide fasteners not only for normal tangent and curved track installations, but also for special applications which include:

- Special trackwork fasteners, uniquely designed to provide the necessary high lateral restraint and ease of installation with a minimum number of fastener configurations
- Fasteners for railroad Sealey ore-car dumping, bridge deck, and washer track, specially designed to meet unusual needs for corrosion resistance, electrical isolation, and shock or vibration resistance—or all of these properties at once

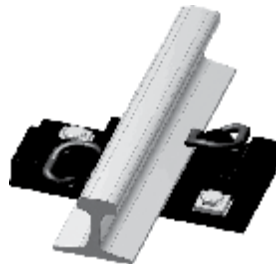

- Mitre rail expansion joint fasteners, designed to function with mitre rail joints for bridges and other special applications that require electrical signal or power isolation, corrosion resistance and vibration/noise attenuation

L.B. Foster Transit Products Division fastener systems are currently installed in the majority of the rail transit systems in North America, including Atlanta's MARTA, Washington's WMATA, San Francisco's BART, Baltimore's MTA, New York City Transit, Los Angeles' MTA, Portland's Tri-Met, the Niagara Frontier Transit in Buffalo, Edmonton LRT and Vancouver's Canada Line.

Other installations include AMTRAK, Climax Molybdenum, and U.S. Steel. Our approach is to adapt to meet your needs. Let us apply our 30 years of track fastening experience to help solve your rail fastening needs.



Special Trackwork Direct Fixation Fasteners

The Transit Products Division has been providing both bonded and non-bonded elastomer direct fixation fasteners for special trackwork applications since the mid-1970's. These fasteners have been supplied to install special track products to either direct fixation surfaces or ties.



Our models have been designed to meet the requirements of our customers and incorporate features to provide:

- Ease of installation and maintenance
- Corrosion resistance
- Electrical stray current resistance
- Noise and vibration dampening

Our various models provide a wide range of performance to meet the requirements such as the following:

- Various longitudinal rail restraints between a high of 4,000 to 5,000 pounds to a low of 0 pounds restraint
- Various vertical and lateral stiffness spring rates to meet light and heavy vehicle wheel load and noise/vibration requirements
- Rigid or resilient rail clips to attach the rail to the fastener body
- Direct installation capability to concrete surface, wood ties or steel structures using appropriate bolting systems

We have fasteners for virtually every special track application, including:

- Turnouts and Crossings
- Restraining Rail

- Miter Rail Joints
- Expansion Joints

Our bonded special trackwork system has adjustments features that significantly ease the installation process and save the installers significant time and money.

Domestic customers include AMTRAK, MARTA in Atlanta, Washington Metro in Washington, DC, Baltimore's MTA, BART and MUNI in San Francisco, Los Angeles' MTA. International customers include Tren Urbano in Puerto Rico, TRTC in Taiwan and Valencia in Venezuela.

If you have an unusual special track installation, we appreciate the opportunity to work with you.



Through years of experience and advances in technology, L.B. Foster Company is pleased to offer a heavy haul alternative to installing rail. The Transit Products Division of L.B. Foster Company has been providing elastomer direct fixation fastener for heavy and industrial applications since the early 1980's. The additional trackload clearance demanded by traditional ballasted track construction can be virtually eliminated through the use of direct fixation rail fasteners. With an average height from rail seat to concrete deck of 1 1/2" to 2", direct fixation fasteners are an ideal alternative whenever height clearances are restricted.

By eliminating the need for sub-ballast, ballast and ties, L.B. Foster's direct fixation fasteners dramatically reduce the track structure height. Also, the lighter system weight allows for more economically designed supporting structures. Less weight means less costs, a savings felt directly at the bottom line.

Accommodating today's demands for double-stack cars presents many railroads with clearance challenges



at existing structures. Retrofitting existing tunnels for additional clearance can be simplified and economized through the use of L.B. Foster Company direct fixation fasteners.



Contact Rails

There are three basic contact rail systems in worldwide use today, and Transit Products can provide whichever fits your system best. Each has its own unique advantages.

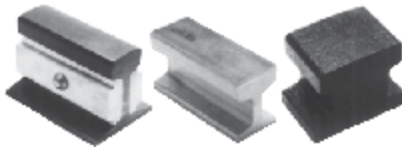

Steel rail/aluminum composite rail consists of aluminum strips fastened to the webbing of conventional or specially designed steel rail. The steel rail provides the height, wear surface, and base; the aluminum strip provides high conductivity. The steel and aluminum elements are joined by Huck-type fasteners assuring good steel-to-aluminum contact.

Aluminum rail is today's most advanced power rail, providing the best available electrical performance per pound of installed weight. The aluminum body is attached to a stainless steel wear strip. The aluminum provides high conductivity, while the stainless steel provides collector shoe wear capability matching that of steel rail.

Traditional non-composite steel rail, of course, has the longest performance record and has served reliably on many systems for over fifty years. At best, however, its electrical performance is half as good as the newer and more advanced systems described above. In addition, steel rail's weight per foot is greater as compared to the other two systems.

Customers include virtually all North American heavy rail transit systems.

Discover the benefits L.B. Foster contact rail's extraordinary performance and economy can bring to your transit operation.



Contact Rail Insulators

L.B. Foster Company has both fiberglass and porcelain insulators for all types of transit and railroad applications. Contact us for any of your insulator installations, whether it be top-running, under-running or side-running contact rail system.

We can offer either stock insulators or develop one specific to your application.

Customers include virtually all North American heavy rail transit systems.

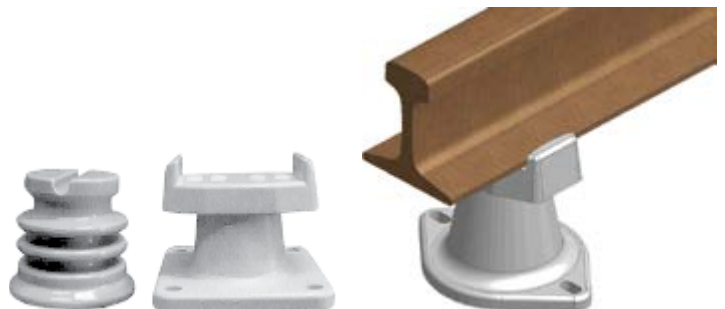

L.B. Foster's Transit Products Division has developed coverboard systems that provide maximum protection for personnel and the power rail at economical prices.

These systems have been installed across North America. Each one has been specifically designed to meet the transit agency's special criteria and to perform effectively under local climate conditions such as wind, snow and ice.

The coverboards are made predominately of a strong, lightweight fiberglass composite which provides high levels of electrical insulation and includes low-smoke, flame-resistant materials. They are easily installed on new or existing systems.

You can see the L.B. Foster Transit Product's coverboard systems in service in many U.S. transit systems—among them Washington's

WMATA, the Baltimore's MTA, Atlanta's MARTA, SEPTA, New York City Transit, Amtrak, San Francisco's BART, and Los Angeles' MTA.

Let us show you one of our existing coverboard systems, or design a new one to meet your special needs.

Discover the difference L. B. Foster Contact Rail Coverboard Systems can make in your transit operation.

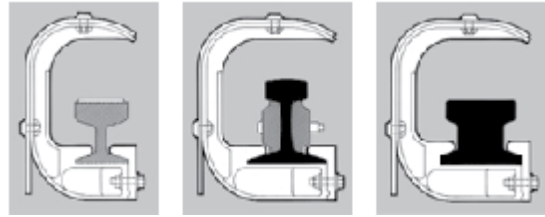

Coverboard Brackets



We have strong coverboard bracket systems that are made from electrical isolating fiberglass material that is proven to withstand a hostile environment. This material and the design of the brackets are such that they will hold the coverboards in place under heavy static and impact loads. The material also electrically isolates the contact power rail from ground. We have brackets for under running, over running and side running contact power rail systems that will work with all types of contact rail.

In addition to the fiberglass bracket systems, we have the steel brackets that attach to the wood ties, concrete ties and other structures.

Contact Rail Appurtenances

As part of the various contact rail systems that L.B. Foster Company can provide we offer end approaches (ramps/inclines), expansion joints, anchor systems, concrete tie extensions and concrete insert

systems designed and proven to work. Let us provide you with our complete contact rail system or design one to meet your specific needs.



Embedded Track Systems

The L.B. Foster Company rail boot system allows for dynamic movement of the rail when embedded in concrete, asphalt or other material to protect the surrounding materials. It also provides electrical isolation and noise and vibration mitigation. Our product is designed to install easier than any other available rail boot system.

The complete system includes splice cuffs, adhesive, filler, tape, plates, clips and leveling beams. Levelling beams which are used for mounting and holding the rail in position for track embedment, can be offered in steel or composite material. Configurations are available for a variety of rail sections.

Customers include Herzog in Sacramento and Phoenix, Stacy Witbeck in Phoenix, SEPTA, Port Authority of Allegheny County in Pittsburgh, G.W. Peoples in Norfolk, Virginia and others.

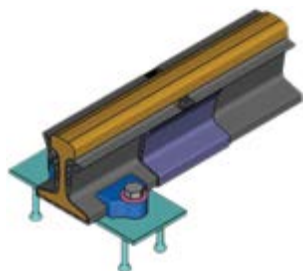

The Transit Products Division of L.B. Foster Company first supplied two block tie and rubber boot systems in the early 1980's. This product is designed to provide our customers with the following:

- Rapid yet efficient slab track construction under certain conditions
- Noise and vibration mitigation in certain frequency ranges
- Electrical leakage prevention
- Improved lateral restraint in curved ballasted applications

Customers include Baltimore MTA.



Concrete Inserts



L.B. Foster Company has provided in excess of two million concrete inserts in varying configurations for anchoring materials to concrete track beds. Anchored materials may include direct fixation fasteners, restraining rail and guard rail, power rail insulators or power rail anchor assemblies. Our various designs can be furnished plain, zinc plated or epoxy coated for electrical isolation. Complete testing for pullout strength has been performed and is available for all insert types.

Ballast Mats

Ballast mats provide our customers with quieter transit systems and railroads. They are easy to install and very effective in reducing structure borne sound due to rail traffic. They are effective in ballast track, embedded street track systems and floating slab systems. Ballast mats also provide electrical isolation for stray currents from the track to surrounding structures.

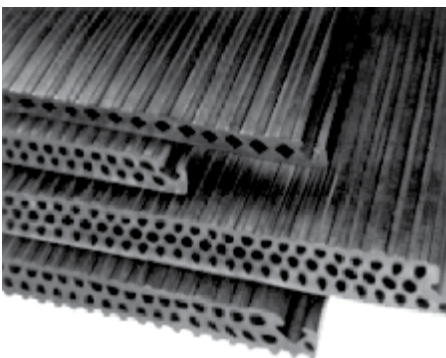

Transit Product's engineering and product development capabilities may be summarized as follows:

- Product design and development
- Product evaluation and testing
- Comprehensive mechanical testing laboratory
- In-house 3D modeling and finite element analysis capability
- Ongoing applied research on track components and new materials in track applications
- Capability of custom designing a product from concept to functional product based on customer needs



Insulator Finite Element Analysis Example

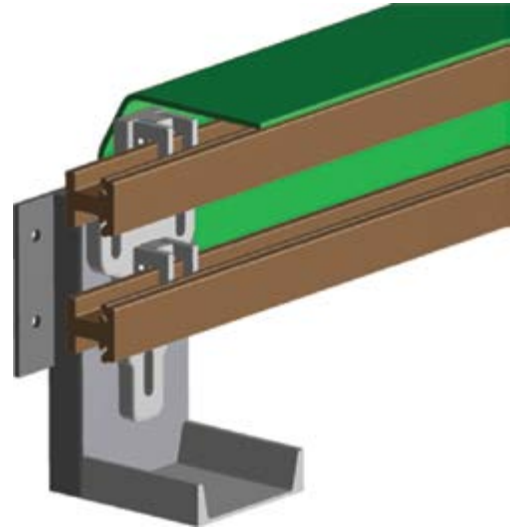

Two Conductor Rail Insulator and Coverboard Design

Testing Services

Transit Products testing laboratory was developed specifically for the needs of the transit and railroad industries. We serve transit agencies, system designers, transit system contractors, and suppliers of products used in transit systems.

The laboratory can perform a wide range of product tests through static loading, structural fatigue, electrical and environmental simulations. Employing state-of-the-art equipment, our trained personnel can help you determine the durability and effectiveness of components or systems under simulated field conditions. Structural testing facilities include closed loop force control systems, that can mimic static and dynamic cyclic loading.

Each test system consists of main frames, hydraulic actuators, force transducers, and monitoring instrumentation.

The actuators can be manually or automatically controlled by an external source which can be programmed to provide virtually any loading or cycling. Monitoring facilities include a dynamic display console, hard copy data printing, and continuous strip chart recording.

These allow the laboratory to capture extensive and accurate data over extended time periods. With these facilities, the Transit Products testing laboratory has performed major programs of static, fatigue, and wear testing. We have tested power rail, direct fixation fasteners, two-block ties, embedded track and ballasted track components.

Electrical testing facilities include both AC and DC test equipment, capable of testing conductivity and insulating ability of a wide variety of electrical components and systems.

The DC equipment is capable of test voltages up to 15,000 volts, with current capacities within 4.6 milliamps. DC resistance tests can be run over the entire range from 1 microhm to 200 million ohms.

Tests that have been performed include: AC and DC resistance, high voltage flashover, current flow and many other customized electrical testing. Environmental testing capabilities include heat aging, cooling, water absorption, and salt spray.

Let Transit Products test engineers study your design verification requirements and develop a test plan to meet your needs.



YOUR LEADING RAIL INDUSTRY SOLUTIONS PROVIDER

TRACK INFRASTRUCTURE PRODUCTS
WHEEL INTERFACE SOLUTIONS
RAIL CONDITION MONITORING

CONTACT INFORMATION:

United States: 1.800.255.4500 or 1.412.928.3400

International: +44(0) 1142562225